

OWNER MANUAL

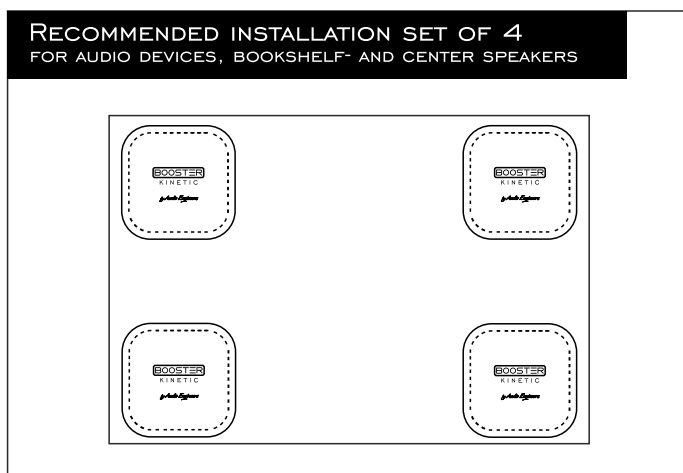

CRYSTAL PARTICLE DAMPING TECHNOLOGY VIBRATION CONTROL SYSTEM

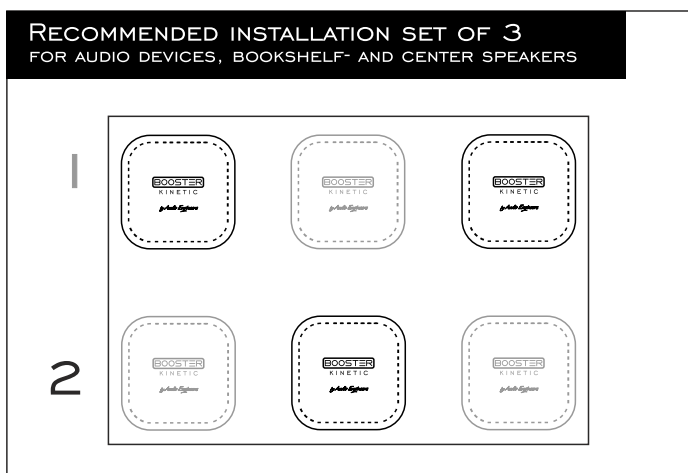
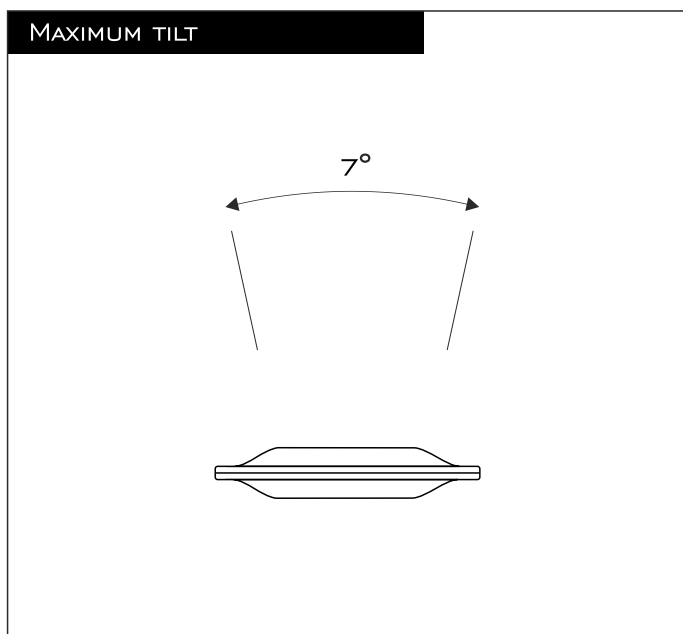
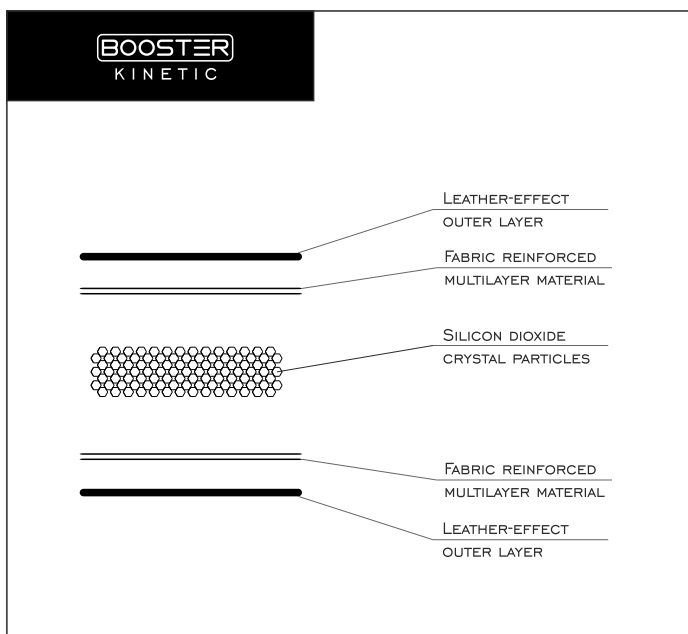
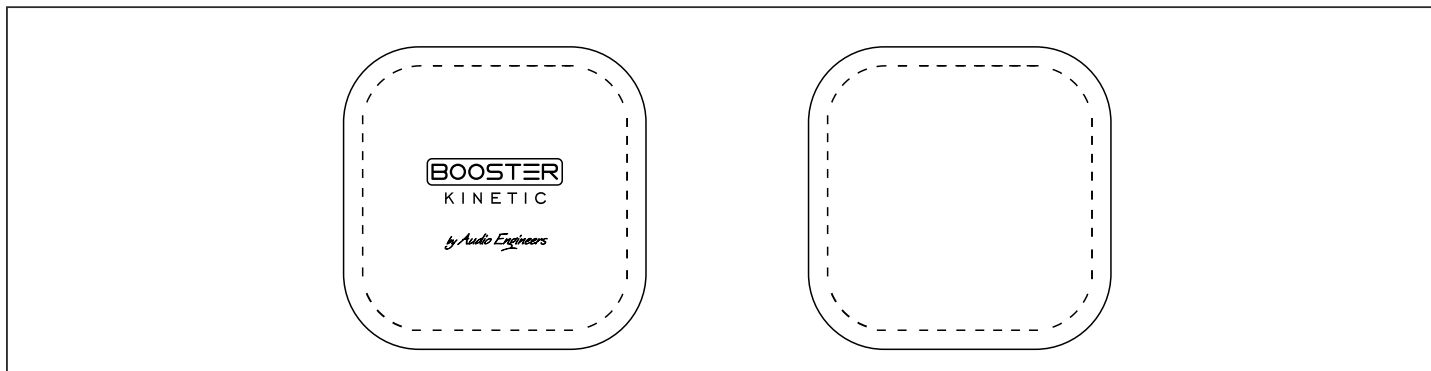

RECOMMENDED INSTALATIONS

FOR AUDIO DEVICES, BOOKSHELF- AND CENTER SPEAKERS

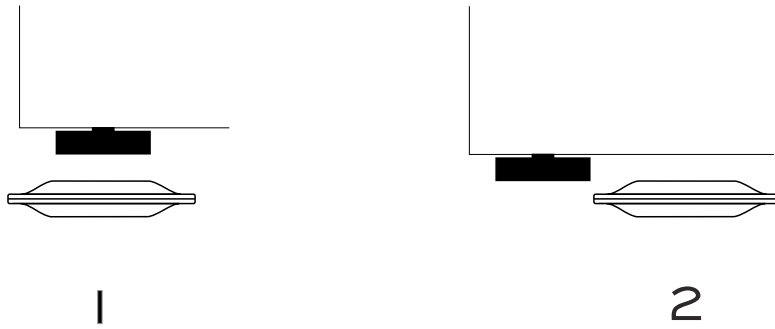

NOTE: DO NOT PLACE POINTED OR SHARP OBJECTS ON THE BOOSTER KINETIC ISOLATION PADS AS THEY MAY DAMAGE THE OUTER CASING. DO NOT PLACE HEAVIER DEVICES THAN THE MAXIMUM LOAD ON THE BOOSTER KINETIC ISOLATION PADS. THE SPECIFIED LOAD CAPACITY IS FOR ONE PIECE ISOLATION PADS. BOOSTER KINETIC ISOLATION PADS CAN BE CLEANED WITH A SOFT CLOTH AND MILD SOAPY WATER, NOT WASHED.

DESIGNED AND ENGINEERED IN THE UK.
MADE WITH PRECISION HAND ASSEMBLY IN THE EU.

SPECIFICATION:

COLOR: SOFT BLACK
MATERIALS: SOFT LEATHER-EFFECT MATERIAL, MULTILAYER FIBER REINFORCED
FABRIC, SILICON DIOXIDE CRYSTAL GRAINS
DIMENSIONS: 2,55" x 2,55" x 0,55" / 65 x 65 x 15 MM (APPROX)

WEIGHT: 0,1 LBS / 40G / 1 PC
LOAD CAPACITY: 22 LBS / 10KG / 1 PC

WWW.AUDIOENGINEERS.EU



DESIGNED &
ENGINEERED
IN THE UK

by Audio Engineers